

IEEE1394.b Interface Progressive Scan Color Cameras

**KP-FD140F**      **KP-FD32F**



**IEEE1394.b Interface**

- The IEEE1394.b interface allows direct high speed data transfer between the camera and the PC using a small 8 conductor cable.
- The 800 Mbps transfer speed of the IEEE-1394.b interface permits higher frame rates for high resolution cameras.
- Multiple cameras can share the IEEE-1394.b bus using a simple daisy chain connection.

**The lineup**

- **KP-FD140F** 1.45 million pixels for high resolution (SXGA) at 15 frames per second. Designed for High Resolution color inspection.
- **KP-FD32F** 330,000 pixels for standard resolution (VGA) at a high frame rate of 60 frames per second. Designed for high speed inspection.

**Versatile features support many applications**

- Electronic shutter
- Hardwired Trigger
- White balance
- Daisy chain
- External sync
- Partial scan
- Independent 6 color masking
- Remote control

**Connection example**

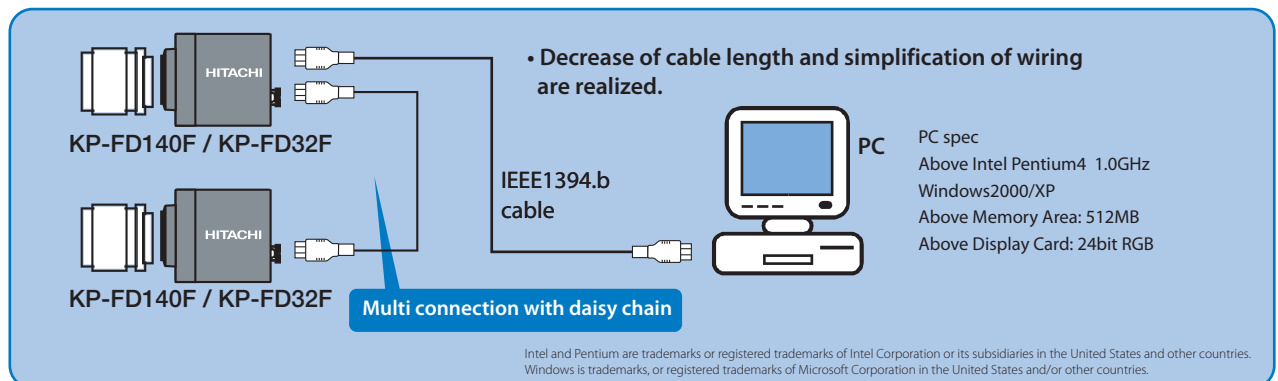

Intel and Pentium are trademarks or registered trademarks of Intel Corporation or its subsidiaries in the United States and other countries. Windows is trademarks, or registered trademarks of Microsoft Corporation in the United States and/or other countries.

## Main Specifications

	KP-FD140F	KP-FD32F
<b>Imaging device</b>	1/2-inch interline type all pixel read-out system CCD	
<b>Total pixels</b>	1434(H) x 1050(V)	692(H) x 504(V)
<b>Effective pixels</b>	1392(H) x 1024(V)	656(H) x 492(V)
<b>Pixel pitch</b>	4.65 μm(H) x 4.65 μm(V) [square lattice]	9.9 μm(H) x 9.9 μm(V) [square lattice]
<b>Scanning system</b>	Progressive scan	
<b>Synchronization</b>	Internal/external (automatic switching)	
<b>Picture signal output</b>		
<b>Interface</b>	IEEE1394.b (FireWire800)	
<b>Protocol</b>	IEEE1394-based Digital Camera Specification Version 1.31 Conformity	
<b>Transmission speed</b>	800 / 400 / 200 Mbps	
<b>Output data form</b>	RGB24/YUV(4:2:2) / Raw8 / Raw16	
<b>Output picture size</b>	1392(H) x 1024(V) 1280(H) x 960(V) 1024(H) x 768(V) 800(H) x 600(V) 640(H) x 480(V)	656(H) x 492(V) 640(H) x 480(V)
<b>Frame rate</b>	15 frames/second (RGB24, 1392(H) x 1024(V))	60 frames/second (RGB24, 656(H) x 492(V))
<b>The minimum photographic subject illumination</b>	25 lx (F1.4, maximum gain)	20 lx (F1.4, maximum gain)
<b>Gain</b>	Automatic / manual (0 dB to 18dB)	
<b>Electronic shutter speed</b>	Automatic(AES) / manual operation(VARIABLE) 1/1000000 second to 10 second	
<b>External trigger</b>		
<b>Mode</b>	Fixed shutter (Mode 0), one trigger (Mode 1)	
<b>Input</b>	1394 Cable course (Software trigger), Our company original system (Hardware trigger)	
<b>Current consumption</b>	Approx. 3.8 W (DC+12 V)	Approx. 3.6 W (DC+12 V)
<b>Automatic picture level control (ALC)</b>	Picture level adjustment is possible	
<b>White balance control</b>	ATW / MANUAL / One-push	
<b>Gamma</b>	OFF / LUT	
<b>Color masking</b>	OFF / ON (6 color independence masking)	
<b>Color saturation</b>	Adjustment is possible.	
<b>Sharpness</b>	Adjustment is possible.	
<b>Brightness</b>	Adjustment is possible.	
<b>Daisy chain</b>	Connection is possible.	
<b>Lens mount</b>	C mount (With a flange back adjustment mechanism)	
<b>Power supply</b>	DC +8 V to +30 V (It supplies from an IEEE1394 cable)	
<b>Ambient</b>		
<b>Operating</b>	0 to +40 °C (+32 to ; 104 °F), 30 to 80%RH * If operated continuously, be sure to use at less than +40 °C(104 °F) for long term stable performance.	
<b>Storage</b>	-10 to +50 °C (+14 to +122 °F), 20t o 90%RH	
<b>Vibration endurance</b>	less than 68.65 m/s <sup>2</sup> (It is the XYZ direction 30 minutes each about 10 to 200Hz) *Please do not add a strong vibration over a long time	
<b>Shock endurance</b>	less than 490.3 m/s <sup>2</sup> (XYZ direction)	
<b>External dimensions</b>	44(W) x 44(H) x 54(D) mm (A lens is removed.)	
<b>Mass</b>	Approx. 130 g. (A lens is removed.)	
<b>Standard Accessory</b>	Camera body CD-ROM (operation manual, driver software)	

## Dimensions

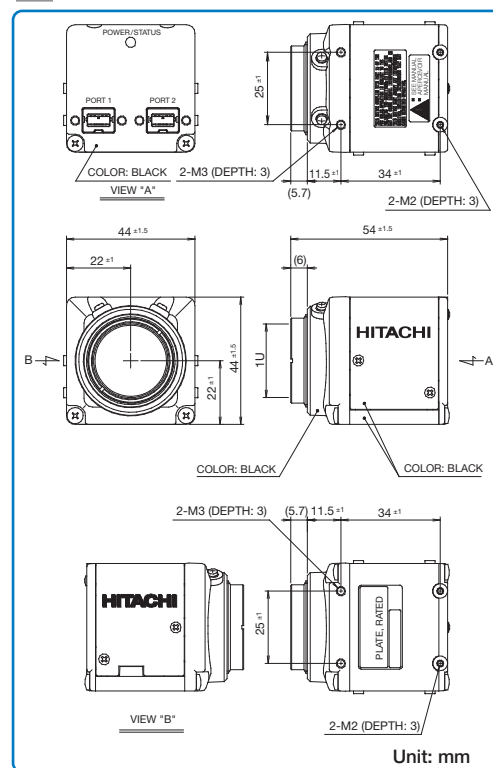

## Rear View



## Optional Accessory

IEEE1394 Cable

Tripod Adaptor